

PANEL HOLE / BOHRUNG DER FRONTPLATTE

For CLB, CNB and CKB
Für CLB, CNB und CKB

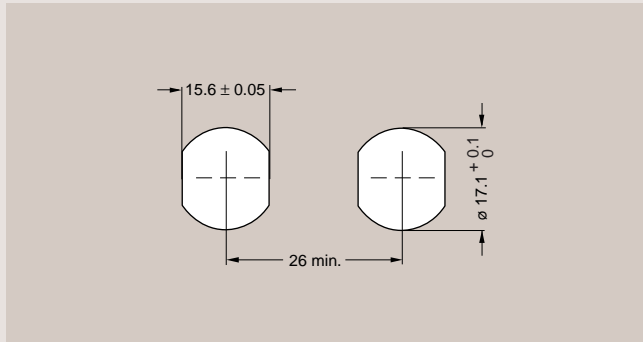

- Socket mounting nut torque = 0.8 Nm.
- Anzugsmoment für Mutter der Apparatedose = 0.8 Nm.

PCB DRILLING PATTERN / BOHRUNG DER GEDRUCKTEN SCHALTUNG

For straight contacts
Für Versionen mit geraden Beinchen

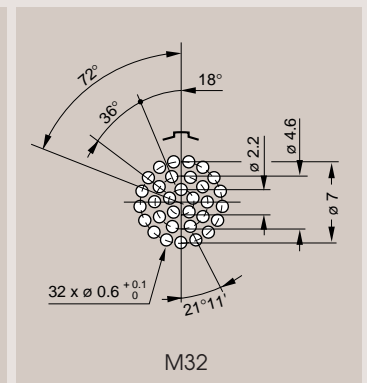
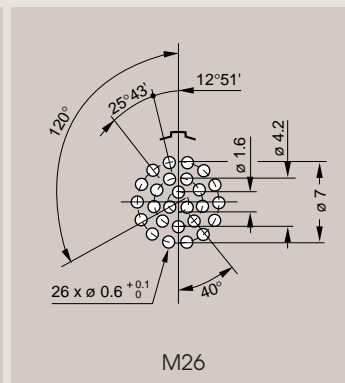
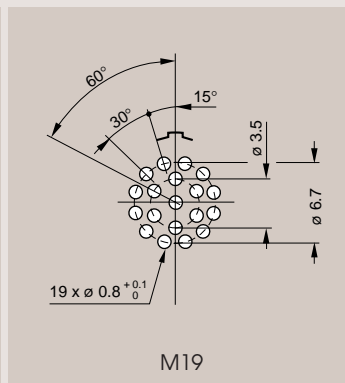
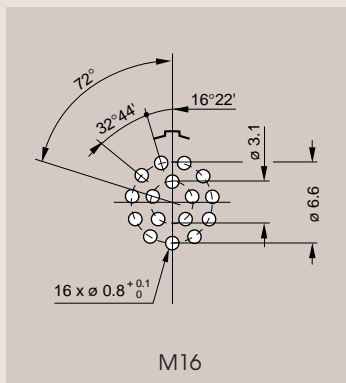

For 90° elbow contacts (A-A view)
Für Winkelkontakte (Sicht A-A)

