

TOOLING / WERKZEUGE

WST Fibre Inspection Microscope
Mikroskop für Faseruntersuchungen



Part number Bestellnummer
WST.FB.G10.4N

WST Epoxy Curing Oven for fibre optic contact
Epoxid Aushärtungssofen für LWL-Kontakt



Part number Bestellnummer	Voltage Spannung
WST.FR.220.VA	220 volts
WST.FR.110.VA	110 volts

DCC Extraction/Installation tool for fibre optic contact
Manipulatorgriffel für LWL-Kontakt

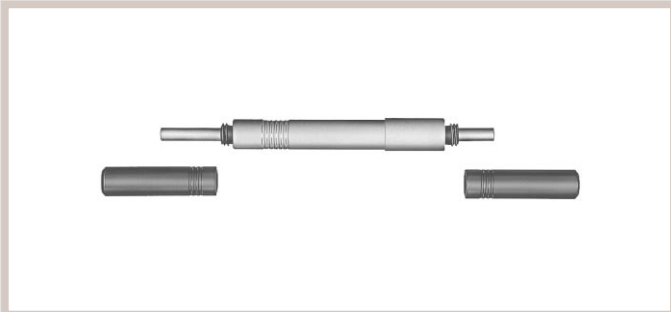

Part number Bestellnummer	Contact type Kontakt Typ
DCC.91.312.5LA	F1, F2

DCS Cleaning tool for F2 contact
Reinigungswerkzeug für LWL-Kontakt F2

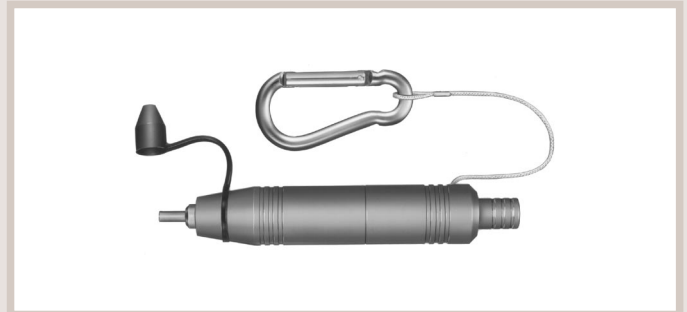

Part number Bestellnummer
DCS.91.F23.LA

PANEL HOLE / BOHRUNG DER FRONTPLATTE

For EGG
Für EGG

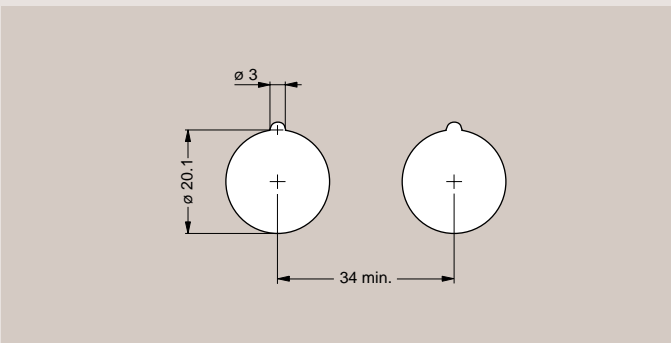

For EBG
Für EBG

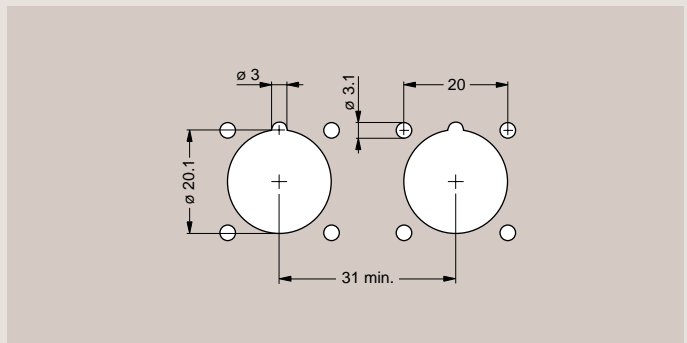

PCB DRILLING PATTERN / BOHRUNG DER GEDRUCKTEN SCHALTUNG

